

FAN WALL Air Handling Unit by *FläktGroup*

AHU's features:

- Up to 1000kW
- Very Large chilled water coil
- Any airflow path
- Any dimensions
- Any filters
- Special Cooling Configurations



Fan Wall Sample Configurations (Airflow)

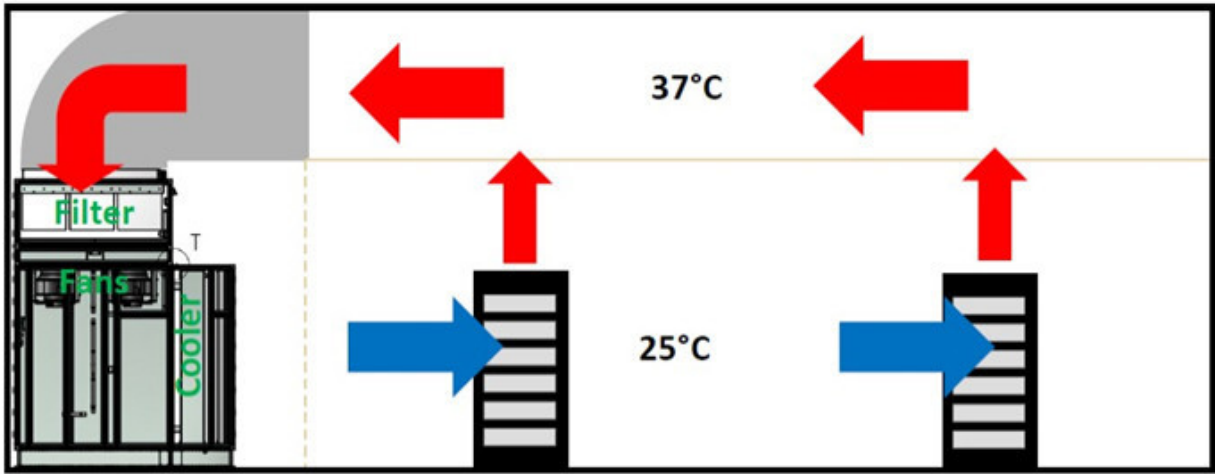

Sample 1

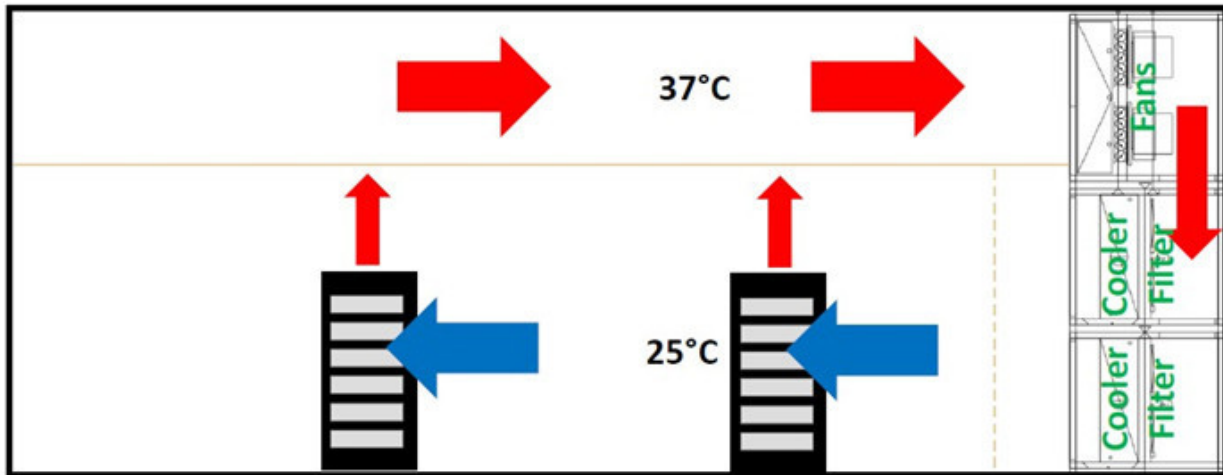

Sample 2

Fan Wall Sample Configurations (Cooling)

Sample 1: Chill Water Type

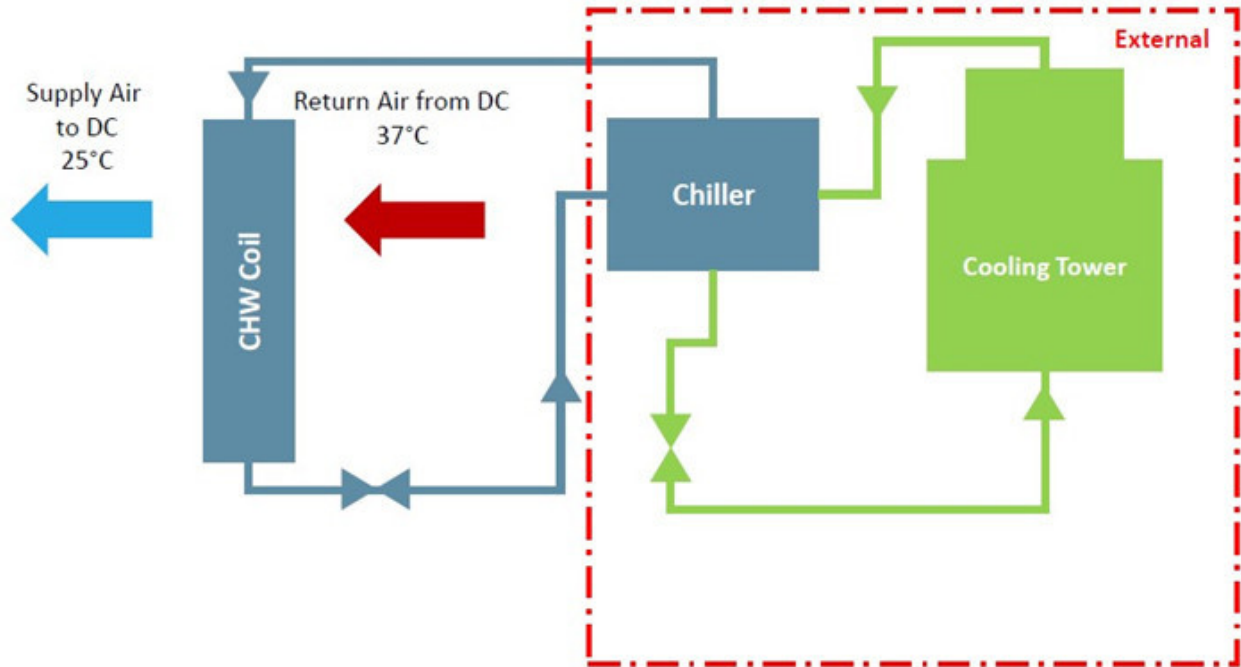

Sample 2: DX Type

